

New Generation Intelligent Cryogenic Nitrogen Plants



CNP20 & CNLab 20 – Compact, Economic and Elegant

CNP20 is a liquid nitrogen plant with a production capacity of 20 lt/day. CNP20 also have its labstation version for applications required only small volumes of liquid nitrogen (LN₂) at a time. Both models arrive as a plug-and-liquify system with a built-in air compressor. A fully integrated design and one button operation allows you to place CNP series liquifiers in the research labs, IVF Centers or clean rooms. Simply, make the electrical connections and produce your own liquid nitrogen by a fully automated operation with a user friendly interface of its PLC controller. Operator only needs to replace the filters and perform routine checks between maintenance intervals of 6500 operating hours.

Liquid nitrogen is produced from air and stored in an internal 60 lt dewar. LN₂ is available when you need it. You can fill your dispensing thermos or transfer LN₂ via a flexible hose to an external dewar with a simple turn on key. LN₂ transfer is independent from the system's operation mode. The PLC automatically re-starts when the level drops to 70%, then will stop the plant when the dewar is full and goes into standby mode until some liquid nitrogen is transferred.

Atmospheric air is elevated to high pressure by a built-in oil free compressor and fed to a buffer tank. The high pressure air in the buffer tank is directed to the filter group behind the unit to remove water droplets and very small particles from the air, then an internal air dryer removes the remaining moisture in the gas phase. The treated dry and clean air with a dew point up to -70°C flows to one of the adsorber beds of the Pressure Swing Adsorption (PSA) module.

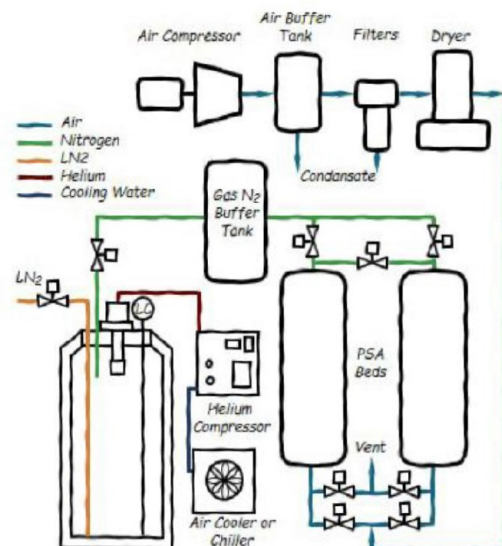

CNO2102

PSA technology can provide nitrogen at the right purity level for liquifier. The carbon molecular sieve in PSA beds adsorbs oxygen and carbon dioxide molecules and after the saturation of the bed, feed flow process valves switch to the second adsorption bed. The first adsorption bed is then depressurized rapidly and purged to remove adsorbed oxygen. By continuing the switching, from one bed to other one generates a constant flow of pure nitrogen gas. The purified nitrogen exposes through a nitrogen buffer tank to a cryogenic storage tank which hosts the cryocooler and other instruments.

Features

- Easy installation,
- Single switch operation,
- LN₂ transfer by one button,
- Control all components through the diagnostic screen,
- Fully automatic start and stop operation by PLC which supports efficient troubleshooting,
- The monitor displays the operational status of the plant and the failures triggered by safety devices and sensors.
- PLC controlled condensate drains on filters
- Easy maintenance on filters



	CNLab20	CNP20
Production Rate	≥ 20 liter/day (≥25 lt/day @ 23 °C)	
Electrical Options	200V~ (5%), 50 Hz 220V~ (5%), 50 Hz 230/240V~ (5%), 50 Hz 208/230V~ (5%), 60 Hz	
Power Consumption (Steady State)	3.5kW @ 50Hz 3.9kW @ 60Hz	
Dimensions	765mm (W) x 1430mm (L) x 1388mm (H)	
Weight	400kg (Empty) / 450kg (Full)	
Suggested Installation Area	2m (W) x 3m (L) x 3m (H)	
Built-in Air Compressor	Built-In Oil-Free Compressor, ≥ 2 m ³ /hour @7 bar (102 psig)	
Cryocooler	GM type cryocooler mounted on Dewar	
Compressor	He, 99.995% purity @ 19-19.3bar (275-280psig), Air Cooled	
Built-in Nitrogen Generator		
Purity	≥ 99%	
Dew Point	up to -40°C	
Flow Rate	≥ 1 m ³ /hour	
Human Machine Interface	6" Color Graphic Touch Screen	
Dewar Volume	60 liter (120 lt optional)	
Operating Pressure	1.5 bar	
Dewar Level Control	Capacitive level sensor	
Ambient Temperature Range	+4°C to +40°C	
Maximum Altitude	3 000 meters	
Noise Level	< 65 dB @ 1 meter	
Standards	CE Conformance – ISO 12100:2010, IEC 60204-1, 2006/42/EC, 97/23/EC; ISO9001:2015	